

HEXKEY EXTENSION ELBOWS

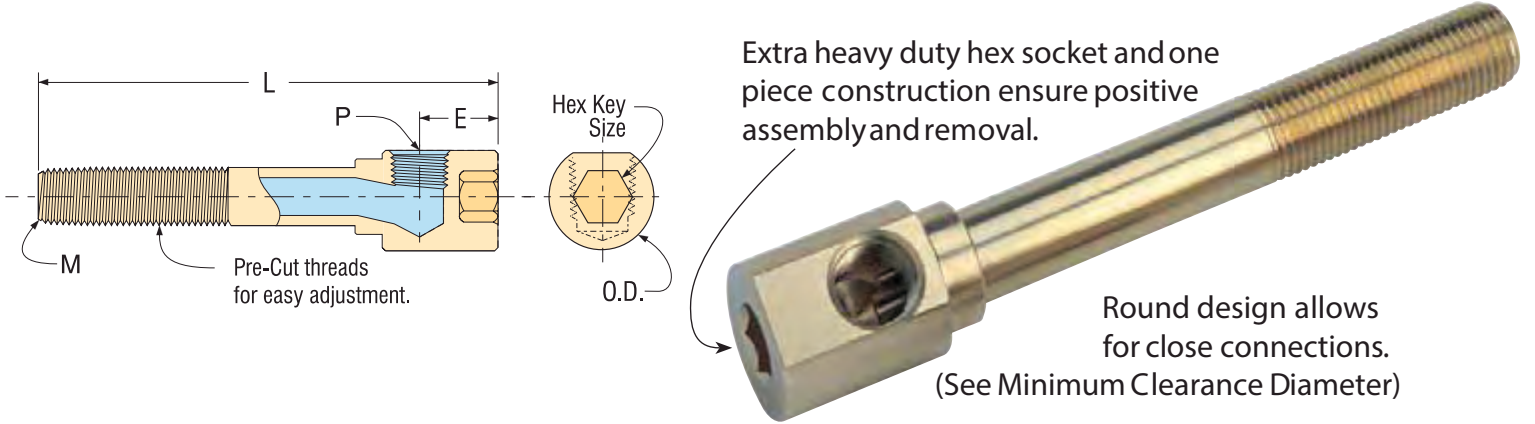

CATALOG NUMBER	P1 TAP SIZE FEMALE (NPT)	P2 TAP SIZE FEMALE (NPT)	L	E	O.D.	MINIMUM CLEARANCE DIAMETER	HEX KEY SIZE
HKL16	1/16	1/16	1.125	0.531	0.552	9/16	1/4
HKL18	1/8	1/8	1.250	0.580	0.615	5/8	5/16
HKL1814	1/8	1/4	1.375	0.593	0.860	7/8	3/8
HKL14	1/4	1/4	1.500	0.660	0.860	7/8	3/8
HKL1438	1/4	3/8	1.625	0.712	0.985	1"	1/2
HKL38	3/8	3/8	1.750	0.780	0.985	1"	1/2
HKL50	1/2	1/2	2.125	0.940	1.235	1-1/4	1/2

HexKey Extension Elbows are round, and install with an Allen wrench. Wrench clearance is not required, making these elbows ideal for use inside the mold, or anywhere space is limited.

- > Angular flow path allows connecting pipe fittings to be torqued tight without choking off flow.
- > Accurate length adjustments are easy with the Brass Extension Plug thread system.

> To order, add overall length to catalog number. Example: EKL16X025

HEX ELBOWS

CATALOG NUMBER	P TAP SIZE FEMALE (NPT)	M PIPE SIZE MALE (NPT)	E	O.D.	MINIMUM CLEARANCE DIAMETER	HEX KEY SIZE	OVERALL LENGTH "L"							
							2-1/2	4"	5-1/2	7"	8-1/2	10"	11-1/2	13"
EKL16	1/16	1/16	0.531	0.552	9/16	1/4	X025	X040	X055	X070	X085	X100	X115	X130
EKL18	1/8	1/8	0.580	0.615	5/8	5/16	X025	X040	X055	X070	X085	X100	X115	X130
EKL14	1/4	1/4	0.660	0.860	7/8	3/8	X025	X040	X055	X070	X085	X100	X115	X130
EKL38	3/8	3/8	0.780	0.985	1"	1/2	X025	X040	X055	X070	X085	X100	X115	X130
EKL50	1/2	1/2	0.940	1.235	1-1/4	1/2	X025	X040	X055	X070	X085	X100	X115	X130

- > Angular coolant path prevents fitting interference at assembly and guarantees full flow. (See Drawing)
- > Compact, round design allows for close connections. (See Minimum Clearance Diameter)

